

# Dell™ Plasma TV

## Owner's Manual

## Notes, Notices, and Cautions



**NOTE:** A NOTE indicates important information that helps you make better use of your TV.



**NOTICE:** A NOTICE indicates either potential damage to hardware and tells you how to avoid the problem.



**CAUTION:** A CAUTION indicates a potential for property damage, personal injury, or death.





**CAUTION:** A CAUTION indicates a potential for property damage, personal injury, or death.

---

**Information in this document is subject to change without notice.**

© 2005 Dell Inc. All rights reserved.

Reproduction of this document in any manner whatsoever without the written permission of Dell Inc. is strictly forbidden.

Trademarks used in this text: *Dell*, the *DELL* logo;  *TruSurround XT*, *SRS*, and  symbol are trademarks of SRS Labs, Inc.

*Dell*, *Dimension*, *OptiPlex*, *Dell Precision*, *Latitude*, *Inspiron*, *DellNet*, *PowerApp*, *PowerEdge*, *PowerConnect*, *PowerVault*, and *EMC<sup>3</sup>* are trademarks of Dell Inc.

Other trademarks and trade names may be used in this document to refer to either the entities claiming the marks and names or their products. Dell Inc. disclaims any proprietary interest in trademarks and trade names other than its own.

November 2005

Rev. A02

# Contents





1	About Your TV	
	<b>Front View</b> . . . . .	5
	<b>Right View</b> . . . . .	6
	<b>Rear View</b> . . . . .	7
	<b>Package Contents</b> . . . . .	9
	<b>Caring for Your TV</b> . . . . .	11
2	Setting Up Your TV	
	<b>Proper Location for Your TV</b> . . . . .	13
	<b>Connecting Your TV</b> . . . . .	14
	<b>Connecting the Speakers</b> . . . . .	20
	<b>Installing the RCA-Phono Cable With Ferrite Core for your TV</b> . . . . .	21
	<b>Image Retention and Burn-In</b> . . . . .	22
3	Your Remote Control	
	<b>Installing Batteries</b> . . . . .	23
	<b>Using Your Remote Control</b> . . . . .	24
	<b>Using Your TV With a Universal or Learning Remote Control</b> . . . . .	26
4	Using the TV Menu	
	<b>Using Your Remote Control With the TV Menu</b> . . . . .	27
	<b>Selecting Your TV Menu Language</b> . . . . .	28
	<b>Input Select</b> . . . . .	28
	<b>Picture Menu</b> . . . . .	30
	<b>Audio</b> . . . . .	30
	<b>PIP/POP/PBP</b> . . . . .	31

	<b>Size</b> . . . . .	<b>32</b>
	<b>Parental Control</b> . . . . .	<b>32</b>
	<b>Setup</b> . . . . .	<b>33</b>
<b>5</b>	<b>Troubleshooting Problems With Your TV</b>	
	<b>Troubleshooting Tips</b> . . . . .	<b>35</b>
	<b>General Problems</b> . . . . .	<b>36</b>
	<b>TV Menu Messages</b> . . . . .	<b>40</b>
	<b>Remote Control Problems</b> . . . . .	<b>40</b>
	<b>Using the Self-Test Feature when Connected to a Computer</b> . . . . .	<b>41</b>
	<b>Problems When Using the TV as a Monitor</b> . . . . .	<b>41</b>
<b>6</b>	<b>Specifications for Your TV</b>	
	<b>Contacting Dell</b> . . . . .	<b>47</b>
	<b>Index</b> . . . . .	<b>65</b>

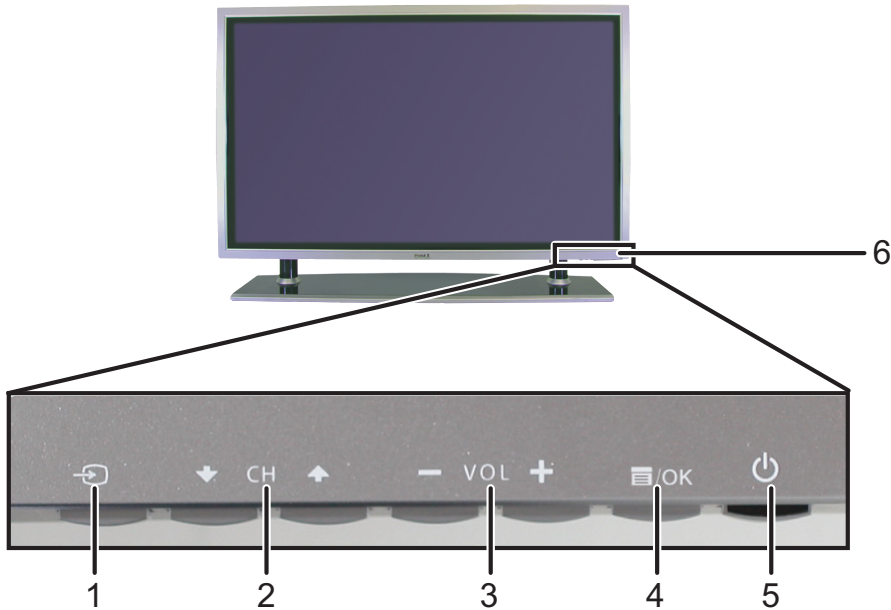
# About Your TV

## Front View



1	 Input Source button	Push to display the Input Select menu
2	 Channel up/down button	Push to select the previous/next channel or navigate through the TV menu
3	 Volume up/down button	Push to increase/decrease the volume or to select an TV menu option
4	 TV Menu button	Push to display the TV menu
5	 Power button and light (LED)	Push to turn the TV on and off The power light is blue when the TV is on and amber when it is in power saving mode
6	IR receiver	Senses the signal from the remote control

## Right View

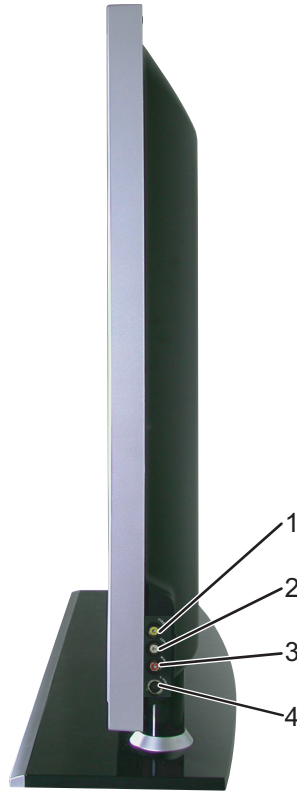

---

1	Composite video connector (SIDE)	Connect devices such as a VCR or DVD player
2	Audio connector (L)	Use this connector if you have connected a device to the composite connector (SIDE) or the S-Video connector (SIDE)
3	Audio connector (R)	Use this connector if you have connected a device to the composite connector (SIDE) or the S-Video connector (SIDE)
4	S-Video input (SIDE)	Connect devices such as a video game system, a digital camera, or a DVD player

---

## Rear View

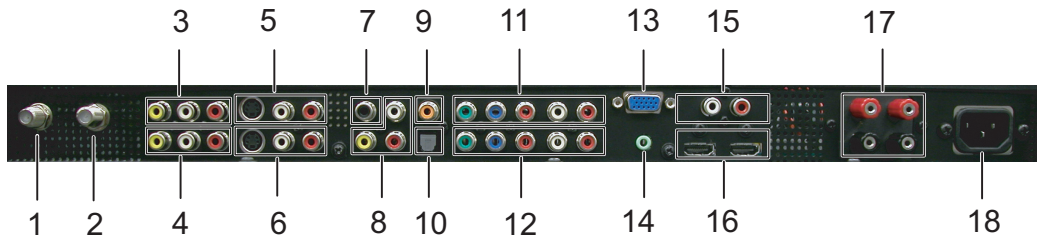

1	ATSC connector	Connect devices such as a DVD player or set-top box
2	NTSC connector	Connect an antenna or a cable TV box
3	Composite video and audio connectors (AV1)	Connect a device such as a VCR or DVD player
4	Composite video and audio connectors (AV2)	Connect a device such as a VCR or DVD player
5	S-Video connectors (AV3)	Connect devices such as a video game system or a DVD player
6	S-Video connectors (AV4)	Connect devices such as a video game system or a DVD player
7	Subwoofer audio out	Connect an optional powered subwoofer to the TV
8	Composite video and audio-out connectors	Connect a device such as a VCR if you have connected an antenna or cable TV through the ANT/Cable connector
9	Coaxial digital audio out	Connect an audio decoder or audio/video receiver when using a Digital TV (ATSC connector)
10	Optical digital out (SPDIF)	Connect an audio decoder or audio/video receiver
11	Component audio and video connectors (AV5)	Connect devices such as a DVD player, set-top box, or cable TV box
12	Component audio and video connectors (AV6)	Connect devices such as a DVD player, set-top box, or cable TV box

---

13	VGA connector	Connect to the VGA cable from your computer to the TV
14	Audio connector for VGA	Connect the audio cable from your computer to the TV
15	DVI audio connectors (R/L)	Connect to the DVI audio connectors if you have connected a device such as a DVD player or set-top box to the HDMI connector with a DVI to HDMI adapter cable
16	HDMI connectors	Connect devices such as a DVD player, set-top box
17	Speaker out connectors	Connect speakers
18	Power connector	Connect your power cord

---



# Package Contents

 **NOTE:** If you need additional cables, contact Dell.

---

Remote control



AAA batteries (3)



Power cord



Audio cable



PC Audio cable



Component cable



Antenna (coaxial) cable



## Documentation

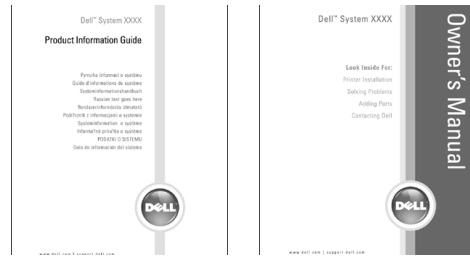

## Wall mount for W4201C and W5001C (optional)

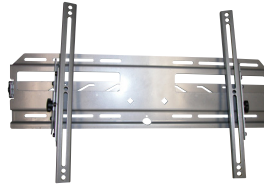

## Speakers for W4201C only



## Speakers for W5001C only



---

Ferrite core (2)



Stand hole cover (2)



 **CAUTION:** Install the covers in the base of the TV when the TV stand is removed to hang the TV on the wall.

---

## Caring for Your TV

 **CAUTION:** Only a licensed technician should service the TV. Do not disassemble the TV.

 **CAUTION:** Before cleaning the TV, unplug it from the electrical outlet.

- To clean the surface of the panel, lightly dampen a soft, clean, lint-free cloth with water.
- To clean the TV cabinet, use a cloth lightly dampened with a mild detergent.
- Do not use chemicals such as benzene, thinner, ammonia, or any type of abrasive cleaner.
- Do not use compressed air to clean the TV.



## Setting Up Your TV



**CAUTION:** Before you begin any of the setup procedures in this section, follow the safety instructions in the Product Information Guide.

### Proper Location for Your TV





Consider the following environmental factors when you are deciding where to put your TV:

- Ensure you allow adequate ventilation.
- Do not store or use the TV in locations that are exposed to high heat, direct sunlight, or extreme cold.
- Avoid moving the TV between locations with high humidity and dusty environments. For more information, see "Specifications for Your TV" on page 43.
- Do not subject the TV to severe vibration or high impact conditions. Do not place the TV inside a car trunk.
- Do not place the TV in a location where water or other liquids could spill on or into the TV.



## Connecting Your TV



The tables below provide a description of the connectors on your TV to help you decide which connectors to use for your various video devices.

### Connecting Your Cable TV Box or Antenna

Quality	Cable and connector	When to Use
Good	Coaxial cable 	Coaxial (RF) cable carries the video and audio signal from the antenna or cable connector to your TV. The coaxial connector is labelled NTSC. To locate the NTSC connector see "Rear View" on page 7.
		
Best	Coaxial cable 	The ATSC cable carries the digital video and audio signal from the antenna connector to your TV. To locate the ATSC connector see "Rear View" on page 7.
		

### Connecting Your Video Devices

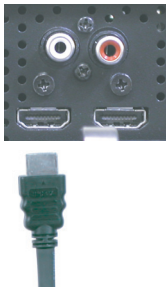

Quality	Cable and connector	When to Use
Good	Composite 	The composite connector carries the video signal through a single pin. If you are using a composite video connector, you also need to connect composite audio cables. To locate the composite connectors, see "Right View" on page 6 and "Rear View" on page 7.
		

Quality	Cable and connector	When to Use
Better	S-Video 	The S-Video connector splits the video signal into two signals, black-and-white and color. If you are using the S-Video connector, you also need to connect the audio cables. To locate the S-Video connectors, see "Right View" on page 6 and "Rear View" on page 7.
Best	Component (YPbPr) 	The component connectors splits the video signal into three signals, two color signals and one black-and-white signal. If you are using the component connectors, you also need to connect the audio cables. To locate the component connectors, see "Rear View" on page 7.
Excellent	HDMI 	HDMI (High Definition Multimedia Interface) assures that the best video signal is always sent from source (HDTV signal, DVD player) to the TV. This is achieved by allowing uncompressed video and multi-channel audio data to be sent to the display device through a single cable. To locate the connector see "Rear View" on page 7.

### Connecting Suborder

Cable and connector	When to Use
Subwoofer 	This connector enables you to connect an optional powered suborder to the TV.

### Connecting Audio Out

Quality	Cable and connector	When to Use
Good 	Composite video and audio out connectors	Use these connectors to connect a device such as a VCR if you have connected an antenna or cable TV through the ANT/Cable connector.
Better 	Coaxial digital audio out	Use the coaxial digital audio out connector to connect an audio decoder or audio/video receiver when using a Digital TV (ATSC) connector.
Best 	Optical digital out	Use the optical digital out connector to connect an audio decoder or audio/video receiver when using a Digital TV (ATSC) receiver.



## Using the ATSC or NTSC Connector (Coaxial)

- 1 Turn off the TV and unplug the power cord.
- 2 Connect the coaxial cable to the ATSC or the NTSC connectors on the TV.
- 3 Plug in the power cord for the TV and turn on the TV.
- 4 Enter the TV Menu and select TV for NTSC or Digital TV for ATSC. See "Input Select" on page 28 for more information.

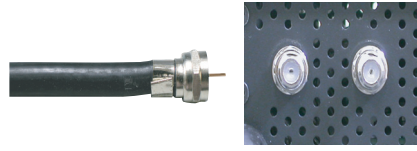

## Using the Composite Connector

- 1 Turn off the TV and unplug the power cord.
- NOTE:** If you are connecting a device that you want to be able to remove, such as a video game system or a camcorder, use the composite connector on the right side of the TV (see "Right View" on page 6).
- 2 Connect your device to the TV using the audio and video cable.
  - 3 Plug in the power cords for the TV and devices and turn them on.
  - 4 Enter the TV Menu and select AV1, AV2 or AV SIDE (Composite 3). See "Input Select" on page 28 for more information.



## Using the S-Video Connector

- 1 Turn off the TV and unplug the power cord.
- NOTE:** If you are connecting a device that you want to be able to remove, such as a video game system, or a camera, use the S-Video connector on the right side of the TV (see "Right View" on page 6).
- 2 Connect your device using the S-Video and audio cables.
  - 3 Plug in the power cords for the TV and devices and turn them on.
  - 4 Enter the TV Menu and select AV3, AV4, or AV SIDE (S-Video 3). See "Input Select" on page 28 for more information.

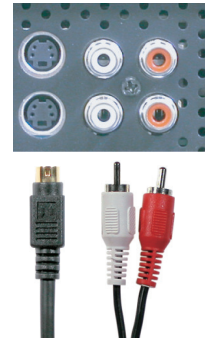

### Using the Component Connector

- 1 Turn off the TV and unplug the power cord.
- 2 Connect your device using the component video and audio cables.
- 3 Plug in the power cords for the TV and devices and turn them on.
- 4 Enter the TV Menu and select AV5 or AV6. See "Input Select" on page 28 for more information.



### Using the HDMI Connector

- 1 Turn off the TV and unplug the power cord.
- 2 Connect your device using the HDMI connector.
- 3 Plug in the power cords for the TV and devices and turn them on.
- 4 Enter the TV Menu and select HDMI1 or HDMI 2. See "Input Select" on page 28 for more information.

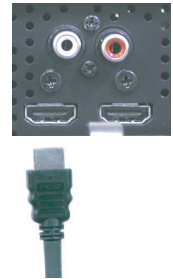

### Using the VGA Connector

- 1 Turn off the TV and unplug the power cord.
-  **NOTE:** Suggest to use a VGA cable which has a ferrite core.
- 2 Connect the VGA and audio cables to your TV and to your computer.
- 3 Plug in the power cords for the TV and devices and turn them on.
- 4 Enter the TV Menu and select VGA. See "Input Select" on page 28 for more information.



### Using the Subwoofer Connector

- 1 Turn off the TV and unplug the power cord.
- 2 Connect a subwoofer cable to your TV and to a powered subwoofer.
- 3 Plug in the power cords for the TV and subwoofer and turn them on.



## Using the Composite Video and Audio Out Connectors

- 1 Turn off the TV and unplug the power cord.
- 2 Connect the video and audio out cables to your TV and to a device such as a VCR if you have connected an antenna or cable TV through the ANT/Cable connector.
- 3 Plug in the power cords for the TV and devices and turn them on.



## Using the Optical Digital Out (SPDIF) Connector

- 1 Turn off the TV and unplug the power cord.
- 2 Connect the optical digital out cable to your TV and to a device such as an audio decoder or audio/video receiver when using a Digital TV (ATSC) receiver.
- 3 Plug in the power cords for the TV and devices and turn them on.



## Using the Coaxial Digital Audio Out Connector

- 1 Turn off the TV and unplug the power cord.
- 2 Connect the coaxial digital audio out cable to your TV and to a device such as an audio decoder or audio/video receiver when using a Digital TV (ATSC) receiver.
- 3 Plug in the power cords for the TV and devices and turn them on.

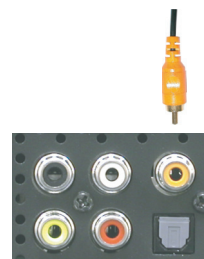

## Connecting the Speakers

### Using the Speakers with the Speaker Stands

- 1 Insert the stands into the speakers.
- 2 Tighten the screws on the speaker.
- 3 Connect the speaker cables to the speaker connectors.

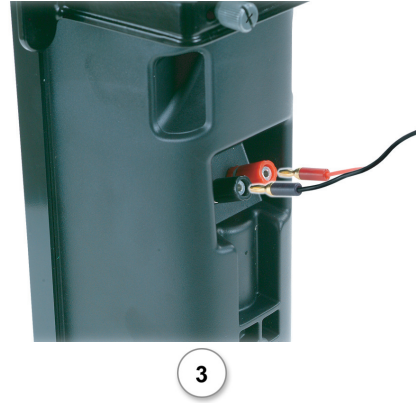

### Attaching the Speakers to the W4201C TV

- 1 Attach the brackets to the speakers and tighten the screws.
- 2 Attach the brackets to the TV and tighten the screws.
- 3 Connect the speaker cables to the speaker connectors.

 **NOTE:** You may use a screwdriver to ensure all screws are completely tightened.



## Attaching the Speakers to the W5001C TV

- 1 Attach the brackets to the speakers and tighten the screws.
- 2 Attach the brackets to the TV and tighten the screws.
- 3 Connect the speaker cables to the speaker connectors.

 **NOTE:** You may use a screwdriver to ensure all screws are completely tightened.



1



2



3

## Installing the RCA-Phono Cable With Ferrite Core for your TV

- 1 Open the attached ferrite core then put the cable inside it.
- 2 Leave 4cm clearance between ferrite core and connector, wind a loop, and then close the ferrite core.
- 3 Repeat steps 1 & 2 to the other end of the connector.
- 4 Connect the DVI audio connectors if you have connected a device such as a PC to the HDMI connectors with a DVI to HDMI cable/dongle.

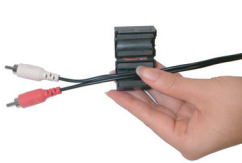

1

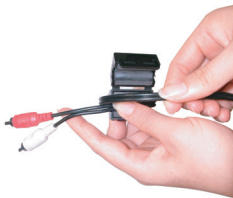

2



3



4

 **NOTE:** DVI to HDMI cable/ dongle and RCA-phono cable are not included with your TV.

## Image Retention and Burn-In

 **NOTE:** Image retention and burn-in are not covered by your Dell warranty.

Displaying an image for an extended period of time can cause an image to remain or burn-in on the screen. Burn-in is a characteristic of all plasma displays.

To help avoid image burn-in, it is best to avoid leaving stationary images on your TV for extended periods of time. Examples of stationary images that may lead to burn-in include:

- TV menus
- Black bars such as those used in 4:3 or wide screen mode
- TV channel logos
- Stock market or news tickers
- Time display
- Shopping channel pricing display
- Static computer images
- Static video game images
- Closed captioning backgrounds

# Your Remote Control

## Installing Batteries

Before you can use your remote control, install three AAA batteries in the remote control as follows.

- 1 Open the battery cover.
- 2 Install the batteries. Make sure that you match the + and - on the batteries with the + and - symbols in the battery compartment.
- 3 Close the battery cover.



# Using Your Remote Control

## Remote Control

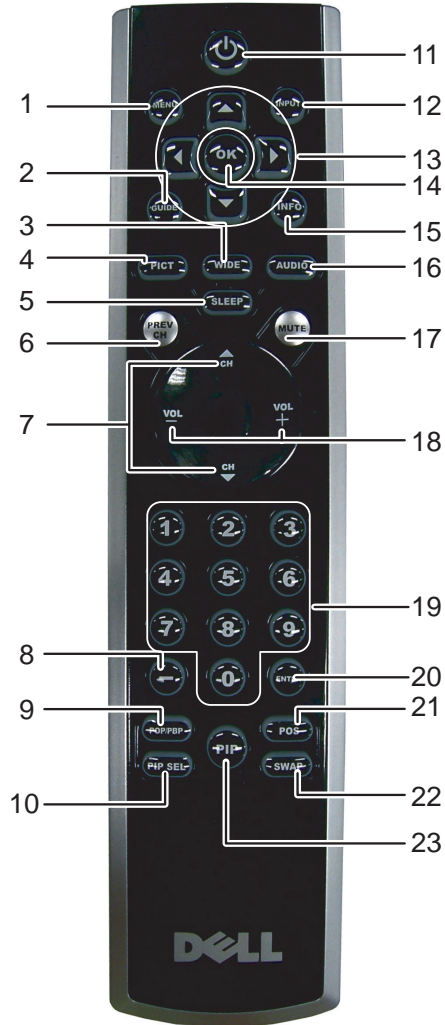



1	MENU	Enters and exits the TV Menu
2	GUIDE	Displays an electronic program guide when using <b>Digital TV</b> (ATSC connector) <b>NOTE:</b> Content may vary depending on the broadcaster
3	WIDE	Sets the screen size
4	PICT	Cycles through the preset options for the <b>Picture</b> menu
5	SLEEP	Turns on the sleep timer
6	PREV CH	Returns you to the previously viewed channel
7	CH ▲ CH ▼	Push to view the next/previous channel
8	-	Press to select digital channels. For example, to select 62-3, press 6, 2, the dash key and then 3 to view the channel
9	POP/PBP	Enters and exits POP or PBP mode
10	PIP SEL	Toggles between windows when you use Picture-in-Picture (PIP), Picture-Outside-Picture (POP), or Picture-By-Picture (PBP)
11	POWER	Turns the TV on and off
12	INPUT	Enters the <b>Input Select</b> menu
13	NAVIGATION	Use these buttons to navigate through the TV Menu
14	OK	Press this button to make or confirm a selection in the TV Menu
15	INFO	Displays information about your TV (for example, in TV mode, it displays the channel you are watching)
16	AUDIO	Cycles through the preset <b>Audio</b> options
17	MUTE	Press to turn the sound on and off
18	VOL + VOL -	Increases/decreases the volume
19	NUMBER	Press to select a channel
20	ENTER	Press to confirm your selection
21	POS	Press to change the position of the PIP window
22	SWAP	Swaps images when using PIP, POP, or PBP
23	PIP	Enters and exits PIP mode

## Using Your TV With a Universal or Learning Remote Control

Preprogrammed universal remote controls can be programmed to control the following functions on your Dell TV:

- Power
- Channel Up (▲)
- Channel Down (▼)
- Volume Up (+)
- Volume Down (-)
- Mute
- Input Select

 **NOTE:** Future preprogrammed universal remote controls may be able to control more functions.

You can program universal remote controls to work with your Dell TV in the following ways:

- If the remote control manual lists codes by manufacturer, use the Phillips codes.
- If the remote control has a search function, this function may be used to find the correct code.
- If the remote control has a learning function, you can program specific buttons on it from the Dell remote control, in addition to those buttons listed above.

 **NOTE:** See the remote control documentation for specific instructions for your universal or learning remote control.

## Using the TV Menu

Your TV has a TV Menu that allows you to select the proper input source, make adjustments to the image and audio settings, select to view Picture-In-Picture, Picture-Outside-Picture, and Picture-By-Picture, and set parental controls.

### Using Your Remote Control With the TV Menu

**NOTE:** You can access and make selections to the TV Menu using the volume and channel buttons on the side panel of the TV or you can use the remote control. Except where noted, this section describes how to use the TV Menu with the remote control.

- 1 To enter the TV Menu, press the **MENU** button.

Eight icons appear along the bottom of the screen.

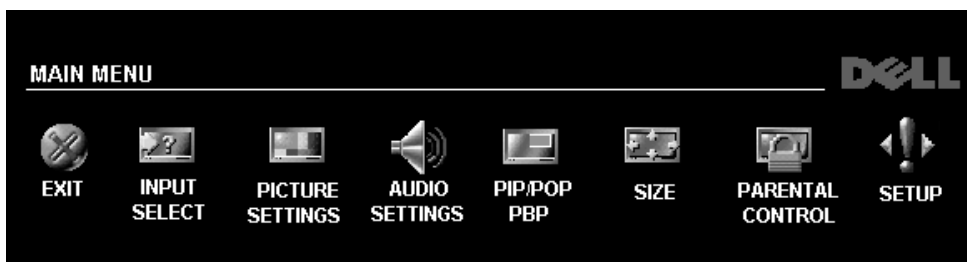

- 2 Use the left and right buttons (volume buttons) to move between the icons. The icon appears highlighted as you move through the menu.
  - 3 To select an option, push the **OK** button when the icon is highlighted.
  - 4 A new menu appears for that selected option. Use the up and down buttons (channel buttons) to move through the various settings.
- NOTE:** A red arrow appears next to the setting as you navigate through the options. A check mark appears next to the option that you have selected.
- 5 Use the left and right buttons (volume buttons) and the **OK** button to adjust or select settings.
- NOTE:** You can select **EXIT** or press the **MENU** button at any time to return to the main menu.
- 6 After you have made your selections, push the **MENU** button to return to the main menu.
  - 7 To exit the TV Menu, select the **EXIT** icon and press **OK**.

## Selecting Your TV Menu Language

- 1 Press **MENU** to enter the TV Menu.
- 2 Select **Setup**.
- 3 In the **Setup** menu, select **Language** and scroll to select the language that you want the TV Menu to appear in.

## Input Select

The **Input Select** menu allows you to select the proper source based on how you have your TV and video equipment connected. Press **Input** on the remote to go directly to the **Input Select** menu. You can also press **Menu** and select **Input Select** from the main menu.

If you are using the **TV** (NTSC connector) or the **Digital TV** (ATSC connector) input source, you can preset the viewable channels. Go to the **Main Menu**, select **Setup**, select **Channel Setup**, and then select **Channel Search**.

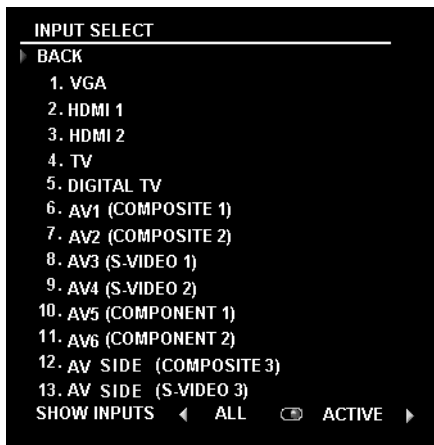

**VGA** — Select when you have your computer connected to the VGA connector. See "Rear View" on page 7 for the location of the VGA connector.

**HDMI1** — Select when you have connected a device, such as a DVD player using the HDMI connector. See "Rear View" on page 7 for the location of the HDMI connector.

**HDMI2** — Select when you have connected a device, such as a DVD player using the HDMI connector. See "Rear View" on page 7 for the location of the HDMI connector.

**TV** — Select when you have your antenna or cable TV box connected to the NTSC connector. See "Rear View" on page 7 for the location of the NTSC connector.

**DIGITAL TV** — Select when you have your antenna connected to the ATSC connector. See "Rear View" on page 7 for the location of the ATSC connector.

**AV1 (COMPOSITE 1)** — Select when you have a video device, such as a video game system, connected to the composite connector on the bottom of the TV. See "Rear View" on page 7 for the location of the composite video and audio connectors.

**AV2 (COMPOSITE 2)** — Select when you have a video device, such as a video game system, connected to the composite connector on the bottom of the TV. See "Rear View" on page 7 for the location of the composite video and audio connectors.

**AV3 (S-VIDEO 1)** — Select when you have a video device, such as a VCR, connected to the S-Video connector on the bottom of the TV. See "Rear View" on page 7 for the location of the S-Video connector.

**AV4 (S-VIDEO 2)** — Select when you have a video device, such as a VCR, connected to the S-Video connector on the bottom of the TV. See "Rear View" on page 7 for the location of the S-Video connector.

**AV5 (COMPONENT 1)** — Select when you have a video device, such as a DVD player, set-top box, or cable TV box, connected to the component audio and video connectors on the bottom of the TV. See "Rear View" on page 7 for the location of the component audio and video connectors.

**AV6 (COMPONENT 2)** — Select when you have a video device, such as a DVD player, set-top box, or cable TV box, connected to the component audio and video connectors on the bottom of the TV. See "Rear View" on page 7 for the location of the component audio and video connectors.

**AV SIDE (COMPOSITE 3)** — Select when you have a video device, such as a video game system, connected to the composite connector on the bottom of the TV. See "Rear View" on page 7 for the location of the composite video and audio connectors.

**AV SIDE (S-VIDEO 3)** — Select when you have a video device, such as a VCR, connected to the S-Video connector on the side of the TV. See "Right View" on page 6 for the location of the S-Video connector.

**SHOW INPUTS** — Show Inputs allows you to select Active or All. Active searches for which connectors are being used. The available input sources appear in white and input sources that are not available appear in grey. All shows all the input sources and allows you to select all the input sources even if you do not have a device connected.



**NOTE:** In TV Menu Settings, located in the Setup menu, you can set the Input Select to display the device that you have attached. For example, AV2 would say DVD when you view the Input Select menu.

## Picture Menu

The Picture Menu allows you to adjust the appearance of the image including color and brightness.

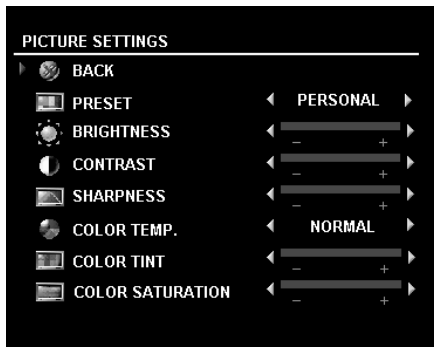

If you select one of the following preset image settings the individual settings are automatically updated.

- Movies
- Sports
- Weak Signal
- Multimedia

If you select **Personal**, you can adjust the individual settings, such as **Brightness** and **Color**.

The color temperature presets are:

- Natural: 6500K
- Normal: the native panel temperature
- Blue: 9300K
- Red: 5700K

## Audio

The Audio Menu allows you to set the audio to best fit the type of show you are watching.



**SRS TruSurround XT**— Delivers virtual surround sound over two speakers from any source, which creates a wider sound with deep rich bass.

**Midnight Mode** — Evens out the large volume variations between voice and action scenes.

**Equalizer Mode** — If you select one of the following preset **Equalizer Mode** settings, the individual audio levels are automatically updated:

- Music
- Theater
- Voice

If you select **Personal**, you can adjust the individual audio levels, such as **Bass** and **Treble**.

**TV Out Volume** — Select **Fixed** if you want to adjust the volume using the remote or volume control on an attached audio receiver. Select **Variable** if you want to adjust the volume using the TV remote or front panel buttons. Using **Variable** adjusts the TV volume out not the volume on an attached audio receiver.

Use **Program** to select **Stereo**, **Mono**, or **SAP** (Second Audio Program).

**Mute** — Allows you to turn the sound on or off.

**Speaker On/Off** — Allows you turn on or off the sound from the speaker.

## PIP/POP/PBP

You can view two active sources simultaneously using Picture-In-Picture (PIP), Picture-Outside-Picture (POP), or Picture-By-Picture (PBP).

For POP, you can select from three different POP options:

- **POP** — One large POP window to the left and a smaller, centered window on the right.
- **POP3** — One large POP window to the left and three smaller, vertically-aligned windows on the right.
- **POP12** — One large, centered POP window surrounded by twelve smaller windows.

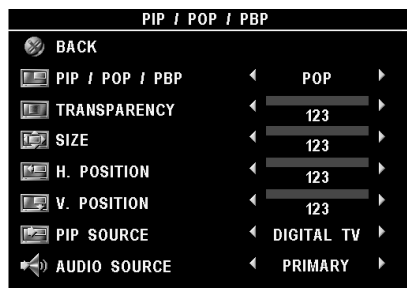

The remote control offers the following PIP/POP/PBP options:

- Use the **PIP SEL** button or the **POP/PBP** button on the remote control to turn on and off PIP, POP, and PBP.
- If you are in PIP, POP, or PBP mode, use the **SWAP** button on the remote control to switch between the two windows.
- Use the **POS** button to change which corner of the screen the PIP window appears.

In the TV Menu, you can adjust the **Transparency**, the **Size**, and **H** (horizontal) and **V** (vertical) position of the PIP/POP/PBP windows. When you are selecting the horizontal orientation, - moves the window left and + moves the window to the right. When you are adjusting the vertical orientation, 0 is at the top of the screen and 100 is at the bottom of the screen.

**PIP Source**— Enables you to select the source for the PIP window. Refer to PIP / POP / PBP compatibility on this page for more information.

**POP Scan Mode**— Enables you to select **Sequential** or **Float**. **Float** mode plays the source for selected channels that appear in the POP windows. **Sequential** rotates through each window and plays all of the preselected channels. The rotation mode runs through all the available channels before it starts again at the lowest channel.

### PIP/POP/PBP Compatibility

When using PIP/POP/PBP you can select any of the input sources that appear in the PIP/POP/PBP windows. The only input sources that cannot work together are HDMI with HDMI, DTV with DTV, and HDMI with Composite 1080i.

## Size

**NOTICE:** Using black bars, such as those seen in Wide or 4:3, for an extended period of time may cause burn-in on your TV.

Size allows you to adjust the appearance of the image. Use **H. Position** to adjust the horizontal placement of the image.



Use the following settings to adjust the aspect ratio:

**Standard** — Best selection for viewing digital HDTV, 16:9 or 22:9 DVD movies.

**Zoom** — Best selection for viewing TV, VCR or 4:3 DVD movie.

**4:3** — Best selection for viewing TV, VCR or 4:3 DVD movie.

**Wide** — Best selection for viewing digital HDTV, 16:9 and 22:9 DVD movies.

**Full Screen** — Best selection for viewing digital HDTV or 16:9 DVD movies.

**Horizontal Shift**— Adjust the horizontal placement of the image.

**NOTE:** Most DVDs have information about the supported aspect ratio on the case.

## Parental Control

Parental Control allows you to block certain channels or programs so children cannot view programs that are not age appropriate.



To enter the Parental Control menu, you need an access code. The first time you enter, use access code 3355. See "Setting an Access Code" on page 33 for information on creating a new access code.

You can set the following options to block content:

- **Channel Lock** — Blocks selected channels
- **Movie Rating** — Blocks movies based on their rating (G, PG, PG-13, R, NC-17, and X)
- **TV Ratings** — Blocks TV shows based on their rating
- **Block Options** — Turns on or off all your parental control settings

**NOTE:** You can use Clear All to unblock the channels and programs that you have set.

**NOTE:** If the Block Control in the Parental Control menu is enabled, all the sub screens in POP (POP1, POP3 and POP12) mode will be blank.



## Setting an Access Code

After you enter the **Parental Control** menu for the first time, you can set your own four-digit access code. If for any reason you lose or forget your access code, you can use the default code.

- 1 In the **Parental Control** menu, select **Change Code**.
- 2 Using the number pad on the remote control, enter a new access code.
- 3 Select **Exit**.

## Setup

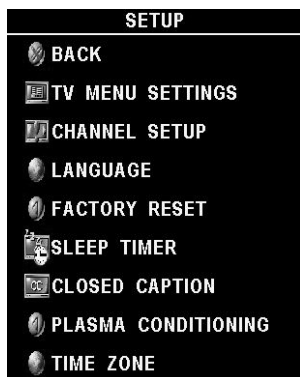

Setup allows you to adjust the appearance of the TV Menu, preset viewable cable channels, change the language of the TV Menu (see "Selecting Your TV Menu Language" on page 28) and to restore factory settings.

In the **TV MENU Settings** menu, use **TV MENU Hold Time** to increase or decrease the amount of time the TV Menu appears. The maximum amount of time is 60 seconds. You can select **TV Button Lock** to lock the buttons on the bottom panel. When this option is enabled, only the power button functions. Hold the volume increase and the channel increase buttons together for 10 seconds to unlock the buttons.

**Channel Setup** allows you adjust the settings for individual channels and preset the viewable channels. If you are using the TV (NTSC connector) or the Digital TV (ATSC connector) input source, you can preset the viewable channels. Go to the **Main Menu**, select **Setup**, select **Channel Setup**, and then select **Channel Search**.

**Language** enables you to choose the TV Menu language.

Select **Factory Reset** to return the TV Menu settings to the factory default values.

 **NOTE:** Before you proceed with the **Factory Reset**, enter a four-digit access code. The **Factory Reset** and **Parental Control** always share the same access code. The default **Parental Control** code is 3355.

 **NOTE:** **Parental Control** setting can be reset by doing factory reset.

**Sleep Timer** allows you to set an increment of time after which the TV automatically turns off.

Select **Closed Caption** to turn on and off closed captioning and set several other CC options.

If an image appears to be stuck on the TV, select **Plasma Conditioning** to help eliminate any image retention. Using the plasma conditioning feature may take several hours. Severe cases of image retention are known as burn-in, the plasma conditioning feature does not remove burn-in.

Use plasma conditioning only when you experience a problem with image retention. Overuse may degrade the TV brightness.

**Time Zone** allow you to set the time zone and daylight saving settings.



**NOTE:** The actual time is set through use of the ATSC tuner with a digital antenna. Without this antenna the time will not be available.

# Troubleshooting Problems With Your TV

 **CAUTION:** If at any time you see smoke or sparks coming from your TV, contact Dell. Do not try to perform any troubleshooting steps.

## Troubleshooting Tips

 **NOTE:** Some problems may be related to video devices connected to your TV. See the video device documentation for additional troubleshooting information.

Most problems with your TV may be caused by not having the correct input selection. Each connector on the TV (side and bottom) is associated with an input selection, which are labelled AV1 through AV SIDE (S-VIDEO 3) in the Input Select menu.

- AV1 — Composite connector on the bottom of the TV
- AV2 — Composite connector on the bottom of the TV
- AV3 — S-Video connector on the bottom of the TV
- AV4 — S-Video connector on the bottom of the TV
- AV5 — Component connector on the bottom of the TV
- AV6 — Component connector on the bottom of the TV
- AV SIDE (COMPOSITE 3) — Component connector on the bottom of the TV
- AV SIDE (S-VIDEO 3) — S-Video connector on the right of the TV

You can also select the following inputs:

- TV — NTSC connector on the bottom of the TV
- DIGITAL TV — ATSC connector on the bottom of the TV
- VGA — VGA connector on the bottom of the TV
- HDMI — HDMI connector on the bottom of the TV

## General Problems

Problem	Possible Solution
Poor picture quality while watching TV and using a device such as a DVD player or a VCR	<ol style="list-style-type: none"> <li>1 Check the aspect ratio settings in the TV Menu. Press the Menu button on the remote control and select Size. For more information on using the TV Menu, see "Using the TV Menu" on page 27.</li> <li>2 Reconnect the device using the same type of connector. For example, if you are using the composite connector on the bottom, try connecting the device to the composite connector on the side of the TV. See "About Your TV" on page 5 for the location of the connectors. After you connect the device, change the input source in the TV Menu. See "Input Select" on page 28 for more information.</li> <li>3 Connect the device using a different connector. For example, if you are experiencing the problem using a composite connector, try using the component connector.</li> </ol> <p><b>NOTE:</b> To connect to a different connector, you need the appropriate cables for that connector. See your device documentation for a list of supported connections.</p> <p>After you connect the device, change the input source in the TV Menu. See "Input Select" on page 28 for more information.</p> <ol style="list-style-type: none"> <li>4 Reset the original factory defaults. Press Menu on the remote control, select Setup, and then select Factory Reset.</li> <li>5 Adjust the color temperature. Press Menu on the remote control, select Picture, and then select Color Temperature.</li> </ol> <p><b>NOTE:</b> Some set top boxes offer aspect ratio. See your device documentation for more information.</p>
Poor picture quality when using a device connected to the ANT/Cable (coaxial) connector	<ol style="list-style-type: none"> <li>1 Ensure TV is selected as the input source in the Input Source menu. See "Input Select" on page 28 for more information.</li> <li>2 Press Menu on the remote control, select Setup, and then select Channel Setup. This resets the channels on your TV.</li> <li>3 Check the aspect ratio settings in the TV Menu. Press the Menu button on the remote control and select Size. For more information on using the TV Menu, see "Using the TV Menu" on page 27.</li> <li>4 Reset the original factory defaults. Press Menu on the remote control, select Setup, and then select Factory Reset.</li> <li>5 Adjust the color temperature. Press Menu on the remote control, select Picture, and then select Color Temperature.</li> <li>6 The problem may be with your device, contact your service provider.</li> </ol>

<b>Problem</b>	<b>Possible Solution</b>
Nothing appears on my TV	<ol style="list-style-type: none"><li>1 Ensure the TV is turned on.</li><li>2 Verify that all the cables are properly connected to the TV, including the power cable.</li><li>3 Check to see if there is a blue or amber light on the lower, right-hand corner of the TV. A blue light indicates the TV is on. An amber light, means the TV is in power save mode.</li><li>4 Ensure the proper source is selected in the Input Source menu. See "Input Select" on page 28 for more information.</li><li>5 Reconnect any devices that are currently connected to the TV. If you are using multiple devices, connect and test one device at a time.</li><li>6 Connect another device that you know is working properly.</li><li>7 Reset the original factory defaults. Press Menu on the remote control, select Setup, and then select Factory Reset.</li></ol>

Problem	Possible Solution
No sound	<ol style="list-style-type: none"> <li data-bbox="646 244 1306 296">1 Ensure mute is not turned on. Pressing the Mute button on the remote control turns the mute function on and off.</li> <li data-bbox="646 305 1306 392">2 If only certain TV channels do not have sound, then you need to correct the Input Select menu in the TV Menu (see "Input Select" on page 28).</li> <li data-bbox="646 401 1306 513">3 Verify that the audio cables are firmly connected to both the audio input connectors on your TV and audio output connectors on your devices. Ensure that the cable colors match the connectors colors.</li> <li data-bbox="646 522 1306 609">4 Also, ensure that the audio cables are connected to the same row as the video cables. See "About Your TV" on page 5 for the location of the connectors.</li> <li data-bbox="646 618 1306 817">5 Reconnect the device using the same type of connector. For example, if you are using the composite connector on the bottom, try connecting the device to the composite connector on the side of the TV. See "About Your TV" on page 5 for the location of the connectors. After you connect the device, change the input source in the TV Menu. See "Input Select" on page 28 for more information.</li> <li data-bbox="646 826 1306 913">6 Connect the device using a different connector. For example, if you are experiencing the problem using a composite connector, try using the component connector.</li> </ol> <p data-bbox="631 921 1306 1008"><b>NOTE:</b> To connect to a different connector, you need the appropriate cables for that connector. See your device documentation for a list of supported connections.</p> <p data-bbox="631 1017 1306 1069">After you connect the device, change the input source in the TV Menu. See "Input Select" on page 28 for more information.</p> <ol style="list-style-type: none"> <li data-bbox="646 1078 1306 1104">7 Test the device on a different TV.</li> <li data-bbox="646 1112 1306 1199">8 If you are using PIP/POP/PBP, ensure the proper Audio Source is selected. Press Menu on your remote control, and select PIP/POP/PBP.</li> </ol>
Double image or no image with DVD	<p data-bbox="631 1216 1306 1364">Turn off the progressive scan on the DVD player. Your Dell™ TV offers built-in deinterlacer that is equal to or better quality than the deinterlacer on your DVD player. For more information about progressive scan on your DVD player, see the documentation for your DVD player</p>
Picture is too dim or too bright	<p data-bbox="631 1373 1306 1433">Update the color settings in the TV Menu. Press Menu on the remote control and select Picture Settings.</p>
The screen is not centered correctly	<ol style="list-style-type: none"> <li data-bbox="646 1442 1306 1494">1 Update the size settings in the TV Menu. Press Menu on the remote control and select Size.</li> <li data-bbox="646 1503 1306 1562">2 Reset the original factory defaults. Press Menu on the remote control, select Setup, and then select Factory Reset.</li> </ol>

<b>Problem</b>	<b>Possible Solution</b>
Screen has one or more lines	<ol style="list-style-type: none"> <li><b>1</b> Check the aspect ratio settings in the TV Menu. Press the Menu button on the remote control and select Size. For more information on using the TV Menu, see "Using the TV Menu" on page 27.</li> <li><b>2</b> Ensure the proper source is selected in the Input Source menu. See "Input Select" on page 28 for more information.</li> <li><b>3</b> Try connecting a different device. Ensure that you properly connect the cables and update the input source in the TV Menu.</li> <li><b>4</b> Update the size settings in the TV Menu. Press Menu on the remote control and select Size.</li> <li><b>5</b> Reset the original factory defaults. Press Menu on the remote control, select Setup, and then select Factory Reset.</li> </ol>
The front panel buttons do not work	<p>Check the TV Menu to see if the buttons have been locked. Press Menu on your remote control, select Setup.</p> <p>If you are unable to use the remote control, press the volume up and the channel up buttons on the bottom of the TV for 10 seconds to unlock the buttons.</p>
The picture is too small	<ol style="list-style-type: none"> <li><b>1</b> Adjust the size settings. Press Menu on the remote control, and select Size.</li> <li><b>2</b> This may be a problem with your device. See the documentation for the device.</li> </ol>
An image appears to be stuck on the TV.	<p>In <b>TV MENU Setup</b> select <b>Plasma Conditioning</b>. Using this option may take several hours before the image is eliminated.</p> <p><b>NOTE:</b> Burn-in is not covered by your Dell warranty.</p>

## TV Menu Messages

While using your TV, the following messages may appear.

Message	Possible Solution
Auto Adjust	No action required, the TV is performing an auto adjustment.
Out of Range	Check the optimal resolution settings. You may need to download a new video driver. For more information, go to <a href="http://support.dell.com">support.dell.com</a> .
No Video Input	<ol style="list-style-type: none"> <li>1 Check all cables are properly connected.</li> <li>2 Ensure the proper source is selected. See "Input Select" on page 28 for more information.</li> </ol>
TV Button Lock	To unlock, press Menu on your remote control, select Setup.
In Power Save Mode Press any key on keyboard or move mouse	If you have a computer connected to the TV display and there is no signal detected, the TV display goes in to sleep mode. The power light is amber when the TV display is in sleep mode.
In Power Save Mode Press Check Video Signal	If you are using a video device and it has been inactive for 30 minutes the TV display goes in to power save mode. The power light is amber when the TV display is in power save mode.
Self Test	Appears for computer source when there is nothing plugged in. Select VGA from Input Select menu and nothing is plugged in. Plug a computer in to the VGA connector.

## Remote Control Problems

Problem	Possible Solution
The TV does not respond when using the remote control	<ol style="list-style-type: none"> <li>1 Point the remote control directly at the lower right corner of the TV. Be sure that nothing is blocking the front of the TV. For the location of the IR, see "Front View" on page 5.</li> <li>2 Verify that the batteries are properly installed.</li> <li>3 If the batteries are old, install new batteries.</li> </ol> <p><b>NOTE:</b> Bright lights or other infrared devices may interfere with your remote control and IR on the TV display.</p>



## Using the Self-Test Feature when Connected to a Computer

When your computer is connected to the TV through VGA connector you can use the self-test feature to check whether your TV is functioning properly. If your TV and computer are properly connected but the TV screen remains dark, run the TV self-test by performing the following steps:

- 1 Turn off both your computer and the TV display.
- 2 Unplug the video cable from the back of the computer.
- 3 Turn on the TV. If the TV cannot sense a video signal and is working correctly, the floating "Dell - Self-Test Feature Check" dialog box appears on the screen (against a black background). While in self-test mode, the power light remains blue and the self-test pattern scrolls through the screen continually. This box also appears during normal system operation if the video cable becomes disconnected or damaged.
- 4 Turn off your TV and reconnect the video cable; then turn on both your computer and the TV. If your TV screen remains blank, the problem may be with your computer or graphic card.

See your computer documentation for more information.

## Problems When Using the TV as a Monitor

Problem	Possible Solution
The picture is off-centered or too small	<ol style="list-style-type: none"> <li>1 Use Auto Adjust to check the Image Settings. Press Menu to enter the TV Menu, select Image Settings, and then select Auto Adjust.</li> <li>2 Check the optimal resolution settings. You may need to download a new video driver. For more information, go to <a href="http://support.dell.com">support.dell.com</a>.</li> </ol> <p><b>NOTE:</b> Some older video cards may not support the resolution settings for the TV.</p>
No audio	<ol style="list-style-type: none"> <li>1 Ensure the green audio cable is connected to audio connector on the TV and on the computer. For the location of the connector on the TV, see "Using the VGA Connector" on page 18. See your computer documentation for the location of connectors on your computer. Do not connect the audio cable to the headphone jack.</li> <li>2 Ensure the volume on the computer is not muted.</li> <li>3 Verify that sound on your computer is working by checking the speakers. See your computer documentation for information on troubleshooting your computer.</li> <li>4 Disconnect the TV from the computer and test to see if the TV volume works.</li> </ol>

<b>Problem</b>	<b>Possible Solution</b>
PIP/POP/PBP not working	<ol style="list-style-type: none"><li>1 Ensure the settings in the TV Menu are properly set. Press Menu to enter the TV Menu, and select PIP/POP/PBP.</li><li>2 Swap the video and audio source.</li></ol>
No video	<p><b>NOTE:</b> If you see a self-test, it means there is a problem with your video card or you are using the wrong input source.</p> <ol style="list-style-type: none"><li>1 Ensure the TV is turned on.</li><li>2 Verify that all the cables are properly connected to the TV, including the power cable.</li><li>3 Check to see if there is a blue or amber light on the lower, right-hand corner of the TV. A blue light indicates the TV is on. An amber light, means the TV is in power save mode.</li><li>4 Ensure proper source is selected. See "Input Select" on page 28 for more information.</li><li>5 Reconnect the computer.</li><li>6 Connect another device that you know is working properly.</li><li>7 Reset the original factory defaults. Press Menu on the remote control, select Setup, and then select Factory Reset.</li></ol>

## Specifications for Your TV

### General

Model number	W4201C	W5001C
Display type	HD PDP panel	HD PDP panel
Screen size	42-inches	50-inches
Viewable area	932 x 532 mm (36.7 x 20.9 inches)	1106 x 622 mm (43.5 x 24.5 inches)
Image aspect ratio	16:9 (wide screen)	16:9 (wide screen)
Video display capabilities	480i 480p 576i 576p 720p 1080i	480i 480p 576i 576p 720p 1080i
Additional features:		
SAP capable	Yes	Yes
CC capable	Yes	Yes
Parental control capable	Yes	Yes

### Physical Dimensions

Display (with stand)	1031.8 x 712.5 x 245.7 mm	1208 x 802.5 x 295.85 mm
Display (no stand)	1031.8 x 631.5 x 83.8 mm	1208 x 923.5 x 89 mm
With Speakers		
Weight (with stand)	46 kg/101.41 lbs (est.)	54.5 kg/120.15 lbs (est.)
Native Resolution	1024 x 768 XGA	1366 x 768 XGA
HDTV Capable	Yes	Yes

---

**Picture-In-Picture**

---

Picture-In-Picture (PIP)	Yes	Yes
Picture-Outside-Picture (POP)	Yes	Yes
Picture-By-Picture (PBP)	Yes	Yes
Number of Tuners	2	2
Panel Brightness	1100	1100
Panel Contrast Ratio	10000: 1	8000: 1

---

**Viewing Angle**

---

Horizontal	+/-80 degree	+/-80 degree
Vertical	+/-80 degree	+/-80 degree

---

**Inputs**

---

## Video

Composite (CVBS)	three in total (side and bottom)	three in total (side and bottom)
S-Video	three in total (side and bottom)	three in total (side and bottom)
Component	two (bottom)	two (bottom)
TV In (coaxial)	two (bottom)	two (bottom)
Audio (RCA L+R)	eight pairs in total (side and bottom)	eight pairs in total (side and bottom)
HDMI	two (bottom)	two (bottom)

## Computer

VGA (for use as computer monitor)	one (bottom)	one (bottom)
Audio (PC)	one (bottom)	one (bottom)

---

**Outputs**

---

## Video

Composite (CVBS)	one (bottom)	one (bottom)
Audio (RCA L+R)	one pair (bottom)	one pair (bottom)
Subwoofer	one	one
SPDIF (RCA + Optical)	one	one

---

**Audio**

---

Effects	SRS TruSurround XT Midnight Mode	SRS TruSurround XT Midnight Mode
Speakers (separate)	20 watts/channel 40 watts total	20 watts/channel 40 watts total



## Contacting Dell

To contact Dell electronically, you can access the following websites:

- [www.dell.com](http://www.dell.com)
- [support.dell.com](http://support.dell.com) (technical support)
- [premiersupport.dell.com](http://premiersupport.dell.com) (technical support for educational, government, healthcare, and medium/large business customers, including Premier, Platinum, and Gold customers)

For specific web addresses for your country, find the appropriate country section in the table below.

**NOTE:** Toll-free numbers are for use within the country for which they are listed.

**NOTE:** In certain countries, technical support specific to Dell Inspiron™ XPS computers is available at a separate telephone number listed for participating countries. If you do not see a telephone number listed that is specific for Inspiron XPS computers, you may contact Dell through the technical support number listed and your call will be routed appropriately.

When you need to contact Dell, use the electronic addresses, telephone numbers, and codes provided in the following table. If you need assistance in determining which codes to use, contact a local or an international operator.

<b>Country (City) International Access Code Country Code City Code</b>	<b>Department Name or Service Area, Website and E-Mail Address</b>	<b>Area Codes, Local Numbers, and Toll-Free Numbers</b>
Anguilla	General Support	toll-free: 800-335-0031
Antigua and Barbuda	General Support	1-800-805-5924
Argentina (Buenos Aires)	Website: <a href="http://www.dell.com.ar">www.dell.com.ar</a>	
International Access Code: 00	E-mail: <a href="mailto:us_latin_services@dell.com">us_latin_services@dell.com</a>	
Country Code: 54	E-mail for desktop and portable computers: <a href="mailto:la-techsupport@dell.com">la-techsupport@dell.com</a>	
City Code: 11	E-mail for servers and EMC® storage products: <a href="mailto:la_enterprise@dell.com">la_enterprise@dell.com</a>	
	Customer Care	toll-free: 0-800-444-0730
	Tech Support	toll-free: 0-800-444-0733
	Tech Support Services	toll-free: 0-800-444-0724
	Sales	0-810-444-3355
Aruba	General Support	toll-free: 800-1578

<b>Country (City) International Access Code Country Code City Code</b>	<b>Department Name or Service Area, Website and E-Mail Address</b>	<b>Area Codes, Local Numbers, and Toll-Free Numbers</b>
<b>Australia (Sydney)</b>	E-mail (Australia): <a href="mailto:au_tech_support@dell.com">au_tech_support@dell.com</a>	
International Access Code: 0011	E-mail (New Zealand): <a href="mailto:nz_tech_support@dell.com">nz_tech_support@dell.com</a>	
Country Code: 61	Home and Small Business	1-300-655-533
City Code: 2	Government and Business	toll-free: 1-800-633-559
	Preferred Accounts Division (PAD)	toll-free: 1-800-060-889
	Customer Care	toll-free: 1-800-819-339
	Technical Support (portables and desktops)	toll-free: 1-300-655-533
	Technical Support (servers and workstations)	toll-free: 1-800-733-314
	Corporate Sales	toll-free: 1-800-808-385
	Transaction Sales	toll-free: 1-800-808-312
	Fax	toll-free: 1-800-818-341
<b>Austria (Vienna)</b>	Website: <a href="http://support.euro.dell.com">support.euro.dell.com</a>	
International Access Code: 900	E-mail: <a href="mailto:tech_support_central_europe@dell.com">tech_support_central_europe@dell.com</a>	
Country Code: 43	Home/Small Business Sales	0820 240 530 00
City Code: 1	Home/Small Business Fax	0820 240 530 49
	Home/Small Business Customer Care	0820 240 530 14
	Preferred Accounts/Corporate Customer Care	0820 240 530 16
	Home/Small Business Technical Support	0820 240 530 14
	Preferred Accounts/Corporate Technical Support	0660 8779
	Switchboard	0820 240 530 00
<b>Bahamas</b>	General Support	toll-free: 1-866-278-6818
<b>Barbados</b>	General Support	1-800-534-3066



<b>Country (City) International Access Code Country Code City Code</b>	<b>Department Name or Service Area, Website and E-Mail Address</b>	<b>Area Codes, Local Numbers, and Toll-Free Numbers</b>
<b>Belgium (Brussels)</b>	Website: support.euro.dell.com	
International Access Code: 00	E-mail for French-speaking Customers: support.euro.dell.com/be/fr/emaildell/	
Country Code: 32	Technical Support for Inspiron XPS computers only	02 481 92 96
City Code: 2	Technical Support for all other Dell computers	02 481 92 88
	Technical Support Fax	02 481 92 95
	Customer Care	02 713 15 65
	Corporate Sales	02 481 91 00
	Fax	02 481 92 99
	Switchboard	02 481 91 00
<b>Bermuda</b>	General Support	1-800-342-0671
<b>Bolivia</b>	General Support	toll-free: 800-10-0238
<b>Brazil</b>	Website: www.dell.com/br	
International Access Code: 00	Customer Support, Technical Support	0800 90 3355
	Technical Support Fax	51 481 5470
Country Code: 55	Customer Care Fax	51 481 5480
City Code: 51	Sales	0800 90 3390
<b>British Virgin Islands</b>	General Support	toll-free: 1-866-278-6820
<b>Brunei</b>	Customer Technical Support (Penang, Malaysia)	604 633 4966
Country Code: 673	Customer Service (Penang, Malaysia)	604 633 4949
	Transaction Sales (Penang, Malaysia)	604 633 4955

<b>Country (City) International Access Code Country Code City Code</b>	<b>Department Name or Service Area, Website and E-Mail Address</b>	<b>Area Codes, Local Numbers, and Toll-Free Numbers</b>
Canada (North York, Ontario)  International Access Code: 011	Online Order Status: <a href="http://www.dell.ca/ostatus">www.dell.ca/ostatus</a>	
	AutoTech (automated technical support)	toll-free: 1-800-247-9362
	Customer Care (Home Sales/Small Business)	toll-free: 1-800-847-4096
	Customer Care (med./large business, government)	toll-free: 1-800-326-9463
	Technical Support (Home Sales/Small Business)	toll-free: 1-800-847-4096
	Technical Support (med./large bus., government)	toll-free: 1-800-387-5757
	Technical Support (printers, projectors, televisions, handhelds, digital jukebox, and wireless)	1-877-335-5767
	Sales (Home Sales/Small Business)	toll-free: 1-800-387-5752
	Sales (med./large bus., government)	toll-free: 1-800-387-5755
Spare Parts Sales & Extended Service Sales	1 866 440 3355	
<b>Cayman Islands</b>	General Support	1-800-805-7541
<b>Chile (Santiago)</b> Country Code: 56 City Code: 2	Sales, Customer Support, and Technical Support	toll-free: 1230-020-4823

<b>Country (City) International Access Code Country Code City Code</b>	<b>Department Name or Service Area, Website and E-Mail Address</b>	<b>Area Codes, Local Numbers, and Toll-Free Numbers</b>
China (Xiamen) Country Code: 86 City Code: 592	Technical Support website: <a href="http://support.dell.com.cn">support.dell.com.cn</a> Technical Support E-mail: <a href="mailto:cn_support@dell.com">cn_support@dell.com</a> Customer Care E-mail: <a href="mailto:customer_cn@dell.com">customer_cn@dell.com</a>	
	Technical Support Fax	592 818 1350
	Technical Support (Dell™ Dimension™ and Inspiron)	toll-free: 800 858 2969
	Technical Support (OptiPlex™, Latitude™, and Dell Precision™)	toll-free: 800 858 0950
	Technical Support (servers and storage)	toll-free: 800 858 0960
	Technical Support (projectors, PDAs, switches, routers, and so on)	toll-free: 800 858 2920
	Technical Support (printers)	toll-free: 800 858 2311
	Customer Care	toll-free: 800 858 2060
	Customer Care Fax	592 818 1308
	Home and Small Business	toll-free: 800 858 2222
	Preferred Accounts Division	toll-free: 800 858 2557
	Large Corporate Accounts GCP	toll-free: 800 858 2055
	Large Corporate Accounts Key Accounts	toll-free: 800 858 2628
	Large Corporate Accounts North	toll-free: 800 858 2999
	Large Corporate Accounts North Government and Education	toll-free: 800 858 2955
	Large Corporate Accounts East	toll-free: 800 858 2020
	Large Corporate Accounts East Government and Education	toll-free: 800 858 2669
	Large Corporate Accounts Queue Team	toll-free: 800 858 2572
	Large Corporate Accounts South	toll-free: 800 858 2355
	Large Corporate Accounts West	toll-free: 800 858 2811
	Large Corporate Accounts Spare Parts	toll-free: 800 858 2621
<b>Colombia</b>	General Support	980-9-15-3978
<b>Costa Rica</b>	General Support	0800-012-0435

<b>Country (City) International Access Code Country Code City Code</b>	<b>Department Name or Service Area, Website and E-Mail Address</b>	<b>Area Codes, Local Numbers, and Toll-Free Numbers</b>
<b>Czech Republic (Prague)</b>	Website: support.euro.dell.com	
International Access Code: 00	E-mail: czech_dell@dell.com	
Country Code: 420	Technical Support	22537 2727
	Customer Care	22537 2707
	Fax	22537 2714
	Tech Fax	22537 2728
	Switchboard	22537 2711
<b>Denmark (Copenhagen)</b>	Website: support.euro.dell.com	
International Access Code: 00	E-mail: support.euro.dell.com/dk/da/emaildell/	
Country Code: 45	Technical Support for Inspiron XPS computers only	7010 0074
	Technical Support for all other Dell computers	7023 0182
	Customer Care (Relational)	7023 0184
	Home/Small Business Customer Care	3287 5505
	Switchboard (Relational)	3287 1200
	Switchboard Fax (Relational)	3287 1201
	Switchboard (Home/Small Business)	3287 5000
	Switchboard Fax (Home/Small Business)	3287 5001
<b>Dominica</b>	General Support	toll-free: 1-866-278-6821
<b>Dominican Republic</b>	General Support	1-800-148-0530
<b>Ecuador</b>	General Support	toll-free: 999-119
<b>El Salvador</b>	General Support	01-899-753-0777
<b>Finland (Helsinki)</b>	Website: support.euro.dell.com	
International Access Code: 990	E-mail: support.euro.dell.com/fi/fi/emaildell/	
Country Code: 358	Technical Support	09 253 313 60
City Code: 9	Customer Care	09 253 313 38
	Fax	09 253 313 99
	Switchboard	09 253 313 00

<b>Country (City) International Access Code Country Code City Code</b>	<b>Department Name or Service Area, Website and E-Mail Address</b>	<b>Area Codes, Local Numbers, and Toll-Free Numbers</b>
<b>France (Paris) (Montpellier)</b>	Website: <a href="http://support.euro.dell.com">support.euro.dell.com</a>	
International Access Code: 00	E-mail: <a href="mailto:support.euro.dell.com/fr/fr/emaildell/">support.euro.dell.com/fr/fr/emaildell/</a>	
Country Code: 33	<b>Home and Small Business</b>	
City Codes: (1) (4)	Technical Support for Inspiron XPS computers only	0825 387 129
	Technical Support for all other Dell computers	0825 387 270
	Customer Care	0825 823 833
	Switchboard	0825 004 700
	Switchboard (calls from outside of France)	04 99 75 40 00
	Sales	0825 004 700
	Fax	0825 004 701
	Fax (calls from outside of France)	04 99 75 40 01
	<b>Corporate</b>	
	Technical Support	0825 004 719
	Customer Care	0825 338 339
	Switchboard	01 55 94 71 00
	Sales	01 55 94 71 00
	Fax	01 55 94 71 01
<b>Germany (Langen)</b>	Website: <a href="http://support.euro.dell.com">support.euro.dell.com</a>	
International Access Code: 00	E-mail: <a href="mailto:tech_support_central_europe@dell.com">tech_support_central_europe@dell.com</a>	
Country Code: 49	Technical Support for Inspiron XPS computers only	06103 766-7222
City Code: 6103	Technical Support for all other Dell computers	06103 766-7200
	Home/Small Business Customer Care	0180-5-224400
	Global Segment Customer Care	06103 766-9570
	Preferred Accounts Customer Care	06103 766-9420
	Large Accounts Customer Care	06103 766-9560
	Public Accounts Customer Care	06103 766-9555
	Switchboard	06103 766-7000

<b>Country (City) International Access Code Country Code City Code</b>	<b>Department Name or Service Area, Website and E-Mail Address</b>	<b>Area Codes, Local Numbers, and Toll-Free Numbers</b>
<b>Greece</b>	Website: <a href="http://support.euro.dell.com">support.euro.dell.com</a>	
International Access Code: 00	E-mail: <a href="mailto:support.euro.dell.com/gr/en/emailldell/">support.euro.dell.com/gr/en/emailldell/</a>	
Country Code: 30	Technical Support	00800-44 14 95 18
	Gold Service Technical Support	00800-44 14 00 83
	Switchboard	2108129810
	Gold Service Switchboard	2108129811
	Sales	2108129800
	Fax	2108129812
<b>Grenada</b>	General Support	toll-free: 1-866-540-3355
<b>Guatemala</b>	General Support	1-800-999-0136
<b>Guyana</b>	General Support	toll-free: 1-877-270-4609
<b>Hong Kong</b>	Website: <a href="http://support.ap.dell.com">support.ap.dell.com</a>	
International Access Code: 001	Technical Support E-mail: <a href="mailto:apsupport@dell.com">apsupport@dell.com</a>	
Country Code: 852	Technical Support (Dimension and Inspiron)	2969 3188
	Technical Support (OptiPlex, Latitude, and Dell Precision)	2969 3191
	Technical Support (PowerApp™, PowerEdge™, PowerConnect™, and PowerVault™)	2969 3196
	Customer Care	3416 0910
	Large Corporate Accounts	3416 0907
	Global Customer Programs	3416 0908
	Medium Business Division	3416 0912
	Home and Small Business Division	2969 3105
<b>India</b>	Technical Support	1600 33 8045
	Sales (Large Corporate Accounts)	1600 33 8044
	Sales (Home and Small Business)	1600 33 8046

<b>Country (City) International Access Code Country Code City Code</b>	<b>Department Name or Service Area, Website and E-Mail Address</b>	<b>Area Codes, Local Numbers, and Toll-Free Numbers</b>
<b>Ireland (Cherrywood)</b>	Website: <a href="http://support.euro.dell.com">support.euro.dell.com</a>	
International Access Code: 16	E-mail: <a href="mailto:dell_direct_support@dell.com">dell_direct_support@dell.com</a>	
Country Code: 353	Technical Support for Inspiron XPS computers only	1850 200 722
City Code: 1	Technical Support for all other Dell computers	1850 543 543
	U.K. Technical Support (dial within U.K. only)	0870 908 0800
	Home User Customer Care	01 204 4014
	Small Business Customer Care	01 204 4014
	U.K. Customer Care (dial within U.K. only)	0870 906 0010
	Corporate Customer Care	1850 200 982
	Corporate Customer Care (dial within U.K. only)	0870 907 4499
	Ireland Sales	01 204 4444
	U.K. Sales (dial within U.K. only)	0870 907 4000
	Fax/Sales Fax	01 204 0103
	Switchboard	01 204 4444
<b>Italy (Milan)</b>	Website: <a href="http://support.euro.dell.com">support.euro.dell.com</a>	
International Access Code: 00	E-mail: <a href="mailto:support.euro.dell.com/it/it/emaildell/">support.euro.dell.com/it/it/emaildell/</a>	
Country Code: 39	<b>Home and Small Business</b>	
City Code: 02	Technical Support	02 577 826 90
	Customer Care	02 696 821 14
	Fax	02 696 821 13
	Switchboard	02 696 821 12
	<b>Corporate</b>	
	Technical Support	02 577 826 90
	Customer Care	02 577 825 55
	Fax	02 575 035 30
	Switchboard	02 577 821
<b>Jamaica</b>	General Support (dial from within Jamaica only)	1-800-682-3639

<b>Country (City) International Access Code Country Code City Code</b>	<b>Department Name or Service Area, Website and E-Mail Address</b>	<b>Area Codes, Local Numbers, and Toll-Free Numbers</b>
<b>Japan (Kawasaki)</b> International Access Code: 001 Country Code: 81 City Code: 44	Website: <a href="http://support.jp.dell.com">support.jp.dell.com</a>	
	Technical Support (servers)	toll-free: 0120-198-498
	Technical Support outside of Japan (servers)	81-44-556-4162
	Technical Support (Dimension and Inspiron)	toll-free: 0120-198-226
	Technical Support outside of Japan (Dimension and Inspiron)	81-44-520-1435
	Technical Support (Dell Precision, OptiPlex, and Latitude)	toll-free: 0120-198-433
	Technical Support outside of Japan (Dell Precision, OptiPlex, and Latitude)	81-44-556-3894
	Technical Support (PDAs, projectors, printers, routers)	toll-free: 0120-981-690
	Technical Support outside of Japan (PDAs, projectors, printers, routers)	81-44-556-3468
	Faxbox Service	044-556-3490
	24-Hour Automated Order Service	044-556-3801
	Customer Care	044-556-4240
	Business Sales Division (up to 400 employees)	044-556-1465
	Preferred Accounts Division Sales (over 400 employees)	044-556-3433
	Large Corporate Accounts Sales (over 3500 employees)	044-556-3430
	Public Sales (government agencies, educational institutions, and medical institutions)	044-556-1469
Global Segment Japan	044-556-3469	
Individual User	044-556-1760	
Switchboard	044-556-4300	
<b>Korea (Seoul)</b> International Access Code: 001 Country Code: 82 City Code: 2	Technical Support	toll-free: 080-200-3800
	Sales	toll-free: 080-200-3600
	Customer Service (Penang, Malaysia)	604 633 4949
	Fax	2194-6202
	Switchboard	2194-6000
	Technical Support (Electronics and Accessories)	toll-free: 080-200-3801



<b>Country (City) International Access Code Country Code City Code</b>	<b>Department Name or Service Area, Website and E-Mail Address</b>	<b>Area Codes, Local Numbers, and Toll-Free Numbers</b>
<b>Latin America</b>	Customer Technical Support (Austin, Texas, U.S.A.)	512 728-4093
	Customer Service (Austin, Texas, U.S.A.)	512 728-3619
	Fax (Technical Support and Customer Service) (Austin, Texas, U.S.A.)	512 728-3883
	Sales (Austin, Texas, U.S.A.)	512 728-4397
	SalesFax (Austin, Texas, U.S.A.)	512 728-4600 or 512 728-3772
<b>Luxembourg</b>	Website: <a href="http://support.euro.dell.com">support.euro.dell.com</a>	
International Access Code: 00	E-mail: <a href="mailto:tech_be@dell.com">tech_be@dell.com</a>	
Country Code: 352	Technical Support (Brussels, Belgium)	3420808075
	Home/Small Business Sales (Brussels, Belgium)	toll-free: 080016884
	Corporate Sales (Brussels, Belgium)	02 481 91 00
	Customer Care (Brussels, Belgium)	02 481 91 19
	Fax (Brussels, Belgium)	02 481 92 99
	Switchboard (Brussels, Belgium)	02 481 91 00
<b>Macao</b>	Technical Support	toll-free: 0800 105
Country Code: 853	Customer Service (Xiamen, China)	34 160 910
	Transaction Sales (Xiamen, China)	29 693 115
<b>Malaysia (Penang)</b>	Website: <a href="http://support.ap.dell.com">support.ap.dell.com</a>	
International Access Code: 00	Technical Support (Dell Precision, OptiPlex, and Latitude)	toll-free: 1 800 88 0193
Country Code: 60	Technical Support (Dimension, Inspiron, and Electronics and Accessories)	toll-free: 1 800 88 1306
City Code: 4	Technical Support (PowerApp, PowerEdge, PowerConnect, and PowerVault)	toll-free: 1800 88 1386
	Customer Service (Penang, Malaysia)	04 633 4949
	Transaction Sales	toll-free: 1 800 888 202
	Corporate Sales	toll-free: 1 800 888 213

<b>Country (City) International Access Code Country Code City Code</b>	<b>Department Name or Service Area, Website and E-Mail Address</b>	<b>Area Codes, Local Numbers, and Toll-Free Numbers</b>
<b>Mexico</b> International Access Code: 00 Country Code: 52	Customer Technical Support  Sales  Customer Service  Main	001-877-384-8979 or 001-877-269-3383 50-81-8800 or 01-800-888-3355 001-877-384-8979 or 001-877-269-3383 50-81-8800 or 01-800-888-3355
<b>Montserrat</b>	General Support	toll-free: 1-866-278-6822
<b>Netherlands Antilles</b>	General Support	001-800-882-1519
<b>Netherlands (Amsterdam)</b> International Access Code: 00 Country Code: 31 City Code: 20	Website: <a href="http://support.euro.dell.com">support.euro.dell.com</a> Technical Support for Inspiron XPS computers only Technical Support for all other Dell computers Technical Support Fax Home/Small Business Customer Care Relational Customer Care Home/Small Business Sales Relational Sales Home/Small Business Sales Fax Relational Sales Fax Switchboard Switchboard Fax	020 674 45 94 020 674 45 00 020 674 47 66 020 674 42 00 020 674 4325 020 674 55 00 020 674 50 00 020 674 47 75 020 674 47 50 020 674 50 00 020 674 47 50

<b>Country (City) International Access Code Country Code City Code</b>	<b>Department Name or Service Area, Website and E-Mail Address</b>	<b>Area Codes, Local Numbers, and Toll-Free Numbers</b>
New Zealand International Access Code: 00 Country Code: 64	E-mail (New Zealand): nz_tech_support@dell.com E-mail (Australia): au_tech_support@dell.com Technical Support (for desktop and portable computers) Technical Support (for servers and workstations) Home and Small Business Government and Business Sales Fax	toll-free: 0800 446 255  toll-free: 0800 443 563  0800 446 255 0800 444 617 0800 441 567 0800 441 566
Nicaragua	General Support	001-800-220-1006
Norway (Lysaker) International Access Code: 00 Country Code: 47	Website: support.euro.dell.com E-mail: support.euro.dell.com/no/no/emaildell/ Technical Support Relational Customer Care Home/Small Business Customer Care Switchboard Fax Switchboard	671 16882 671 17575 23162298 671 16800 671 16865
Panama	General Support	001-800-507-0962
Peru	General Support	0800-50-669
Poland (Warsaw) International Access Code: 011 Country Code: 48 City Code: 22	Website: support.euro.dell.com E-mail: pl_support_tech@dell.com Customer Service Phone Customer Care Sales Customer Service Fax Reception Desk Fax Switchboard	57 95 700 57 95 999 57 95 999 57 95 806 57 95 998 57 95 999

<b>Country (City) International Access Code Country Code City Code</b>	<b>Department Name or Service Area, Website and E-Mail Address</b>	<b>Area Codes, Local Numbers, and Toll-Free Numbers</b>
<b>Portugal</b>	Website: <a href="http://support.euro.dell.com">support.euro.dell.com</a>	
International Access Code: 00	E-mail: <a href="mailto:support.euro.dell.com/pt/en/emailldell/">support.euro.dell.com/pt/en/emailldell/</a>	
Country Code: 351	Technical Support	707200149
	Customer Care	800 300 413
	Sales	800 300 410 or 800 300 411 or 800 300 412 or 21 422 07 10
	Fax	21 424 01 12
<b>Puerto Rico</b>	General Support	1-800-805-7545
<b>St. Kitts and Nevis</b>	General Support	toll-free: 1-877-441-4731
<b>St. Lucia</b>	General Support	1-800-882-1521
<b>St. Vincent and the Grenadines</b>	General Support	toll-free: 1-877-270-4609
<b>Singapore (Singapore)</b>	Website: <a href="http://support.ap.dell.com">support.ap.dell.com</a>	
International Access Code: 005	Technical Support (Dimension, Inspiron, and Electronics and Accessories)	toll-free: 1800 394 7430
Country Code: 65	Technical Support (OptiPlex, Latitude, and Dell Precision)	toll-free: 1800 394 7488
	Technical Support (PowerApp, PowerEdge, PowerConnect, and PowerVault)	toll-free: 1800 394 7478
	Customer Service (Penang, Malaysia)	604 633 4949
	Transaction Sales	toll-free: 1 800 394 7412
	Corporate Sales	toll-free: 1 800 394 7419
<b>Slovakia (Prague)</b>	Website: <a href="http://support.euro.dell.com">support.euro.dell.com</a>	
International Access Code: 00	E-mail: <a href="mailto:czech_dell@dell.com">czech_dell@dell.com</a>	
Country Code: 421	Technical Support	02 5441 5727
	Customer Care	420 22537 2707
	Fax	02 5441 8328
	Tech Fax	02 5441 8328
	Switchboard (Sales)	02 5441 7585

<b>Country (City) International Access Code Country Code City Code</b>	<b>Department Name or Service Area, Website and E-Mail Address</b>	<b>Area Codes, Local Numbers, and Toll-Free Numbers</b>
South Africa (Johannesburg)	Website: support.euro.dell.com	
International Access Code: 09/091	E-mail: dell_za_support@dell.com	
Country Code: 27	Gold Queue	011 709 7713
City Code: 11	Technical Support	011 709 7710
	Customer Care	011 709 7707
	Sales	011 709 7700
	Fax	011 706 0495
	Switchboard	011 709 7700
<b>Southeast Asian and Pacific Countries</b>	Customer Technical Support, Customer Service, and Sales (Penang, Malaysia)	604 633 4810
Spain (Madrid)	Website: support.euro.dell.com	
International Access Code: 00	E-mail: support.euro.dell.com/es/es/emaildell/ <b>Home and Small Business</b>	
Country Code: 34	Technical Support	902 100 130
City Code: 91	Customer Care	902 118 540
	Sales	902 118 541
	Switchboard	902 118 541
	Fax	902 118 539
	<b>Corporate</b>	
	Technical Support	902 100 130
	Customer Care	902 115 236
	Switchboard	91 722 92 00
	Fax	91 722 95 83
Sweden (Upplands Vasby)	Website: support.euro.dell.com	
International Access Code: 00	E-mail: support.euro.dell.com/se/sv/emaildell/	
Country Code: 46	Technical Support	08 590 05 199
City Code: 8	Relational Customer Care	08 590 05 642
	Home/Small Business Customer Care	08 587 70 527
	Employee Purchase Program (EPP) Support	20 140 14 44
	Technical Support Fax	08 590 05 594
	Sales	08 590 05 185

<b>Country (City) International Access Code Country Code City Code</b>	<b>Department Name or Service Area, Website and E-Mail Address</b>	<b>Area Codes, Local Numbers, and Toll-Free Numbers</b>
Switzerland (Geneva) International Access Code: 00 Country Code: 41 City Code: 22	Website: <a href="http://support.euro.dell.com">support.euro.dell.com</a> E-mail: <a href="mailto:Tech_support_central_Europe@dell.com">Tech_support_central_Europe@dell.com</a> E-mail for French-speaking HSB and Corporate Customers: <a href="http://support.euro.dell.com/ch/fr/emaildell/">support.euro.dell.com/ch/fr/emaildell/</a>	
	Technical Support (Home and Small Business)	0844 811 411
	Technical Support (Corporate)	0844 822 844
	Customer Care (Home and Small Business)	0848 802 202
	Customer Care (Corporate)	0848 821 721
	Fax	022 799 01 90
	Switchboard	022 799 01 01
<b>Taiwan</b>	Website: <a href="http://support.ap.dell.com">support.ap.dell.com</a>	
International Access Code: 002 Country Code: 886	E-mail: <a href="mailto:ap_support@dell.com">ap_support@dell.com</a> Technical Support (OptiPlex, Latitude, Inspiron, Dimension, and Electronics and Accessories)	toll-free: 00801 86 1011
	Technical Support (PowerApp, PowerEdge, PowerConnect, and PowerVault)	toll-free: 00801 60 1256
	Transaction Sales	toll-free: 00801 65 1228
	Corporate Sales	toll-free: 00801 651 227
<b>Thailand</b>	Website: <a href="http://support.ap.dell.com">support.ap.dell.com</a>	
International Access Code: 001 Country Code: 66	Technical Support (OptiPlex, Latitude, and Dell Precision)	toll-free: 1800 0060 07
	Technical Support (PowerApp, PowerEdge, PowerConnect, and PowerVault)	toll-free: 1800 0600 09
	Customer Service (Penang, Malaysia)	604 633 4949
	Corporate Sales	toll-free: 1800 006 009
	Transaction Sales	toll-free: 1800 006 006
<b>Trinidad/Tobago</b>	General Support	1-800-805-8035
<b>Turks and Caicos Islands</b>	General Support	toll-free: 1-866-540-3355

<b>Country (City) International Access Code Country Code City Code</b>	<b>Department Name or Service Area, Website and E-Mail Address</b>	<b>Area Codes, Local Numbers, and Toll-Free Numbers</b>
U.K. (Bracknell) International Access Code: 00 Country Code: 44 City Code: 1344	Website: support.euro.dell.com Customer Care website: support.euro.dell.com/uk/en/ECare/Form/Home.asp E-mail: dell_direct_support@dell.com	
	Technical Support (Corporate/Preferred Accounts/PAD [1000+ employees])	0870 908 0500
	Technical Support (direct and general)	0870 908 0800
	Global Accounts Customer Care	01344 373 186
	Home and Small Business Customer Care	0870 906 0010
	Corporate Customer Care	01344 373 185
	Preferred Accounts (500–5000 employees) Customer Care	0870 906 0010
	Central Government Customer Care	01344 373 193
	Local Government & Education Customer Care	01344 373 199
	Health Customer Care	01344 373 194
	Home and Small Business Sales	0870 907 4000
	Corporate/Public Sector Sales	01344 860 456
	Home and Small Business Fax	0870 907 4006
Uruguay	General Support	toll-free: 000-413-598-2521

<b>Country (City) International Access Code Country Code City Code</b>	<b>Department Name or Service Area, Website and E-Mail Address</b>	<b>Area Codes, Local Numbers, and Toll-Free Numbers</b>
U.S.A. (Austin, Texas)	Automated Order-Status Service	toll-free: 1-800-433-9014
International Access Code: 011	AutoTech (portable and desktop computers)	toll-free: 1-800-247-9362
Country Code: 1	<b>Consumer</b> (Home and Home Office)	
	Technical Support	toll-free: 1-800-624-9896
	Customer Service	toll-free: 1-800-624-9897
	DellNet™ Service and Support	toll-free: 1-877-Dellnet (1-877-335-5638)
	Employee Purchase Program (EPP) Customers	toll-free: 1-800-695-8133
	Financial Services website: <a href="http://www.dellfinancialservices.com">www.dellfinancialservices.com</a>	
	Financial Services (lease/loans)	toll-free: 1-877-577-3355
	Financial Services (Dell Preferred Accounts [DPA])	toll-free: 1-800-283-2210
	<b>Business</b>	
	Customer Service and Technical Support	toll-free: 1-800-822-8965
	Employee Purchase Program (EPP) Customers	toll-free: 1-800-695-8133
	Printers and Projectors Technical Support	toll-free: 1-877-459-7298
	<b>Public</b> (government, education, and healthcare)	
	Customer Service and Technical Support	toll-free: 1-800-456-3355
	Employee Purchase Program (EPP) Customers	toll-free: 1-800-234-1490
	Dell Sales	toll-free: 1-800-289-3355 or toll-free: 1-800-879-3355
	Dell Outlet Store (Dell refurbished computers)	toll-free: 1-888-798-7561
	Software and Peripherals Sales	toll-free: 1-800-671-3355
	Spare Parts Sales	toll-free: 1-800-357-3355
	Extended Service and Warranty Sales	toll-free: 1-800-247-4618
	Fax	toll-free: 1-800-727-8320
	Dell Services for the Deaf, Hard-of-Hearing, or Speech-Impaired	toll-free: 1-877-DELLTTY (1-877-335-5889)
U.S. Virgin Islands	General Support	1-877-673-3355
Venezuela	General Support	8001-3605



# Index

## A

- about
  - package contents, 9
  - TV, 5
- access code
  - default, 32
  - parental control, 32
  - setting, 33
- ATSC
  - cable, usage, 14, 16
  - connecting, 17
- audio
  - button, 25
  - connector for VGA, location, 8
  - connectors, location, 6
  - equalizer mode, 30
  - midnight mode, 30
  - OSD menu, 30
  - speaker on/off, 30
  - SRS TruSurround, 30
  - TV out volume, 30
- AV1/AV2. See composite.
- AV3/AV4. See S-Video.
- AV5/AV6. See component.

## B

- block
  - parental control, 32
- button
  - audio, 25

- channel up/down, 5
- enter, 25
- guide, 25
- INFO, 25
- input, 25
- input source, 5
- menu, 25
- mute, 25
- OSD menu, 5
- PICT, 25
- PIP, 25
- PIP SEL, 25
- POP/PBP, 25
- POS, 25
- power, 5
- sleep, 25
- swap, 25
- volume up/down, 5

## C

- channel
  - setup, 28, 33
- channel lock
  - parental control, 32
- coaxial
  - ATSC connector, 17
  - cable, usage, 14, 16
  - digital audio out connector, location, 7
  - NTSC connector, 17
- color temperature, 30
- component

- cable, usage, 15
- video/audio out connectors, location, 7

## composite

- cable, usage, 14, 16
- connecting, 17
- video/audio out connectors, location, 7

## composite video

- connector, location, 6

## computer

- connecting, 18

## connector

- audio left/right, 6
- coaxial digital audio out, 7
- component video/audio out, 7
- composite video, location, 6
- composite video/audio out, 7
- NTSC, 7
- optical digital out, location, 7
- power, 8
- speaker out, 8
- subwoofer, 7
- S-Video, 6-7
- VGA, 8
- VGA audio, 8

## D

## DVI

- connecting, 18-20

- E**
  - enter
    - button, 25
- F**
  - float
    - POP scan mode, 31
- G**
  - guide
    - button, 25
- H**
  - HDMI
    - cable, usage, 15
    - connecting, 18-19
- I**
  - INFO
    - button, 25
  - input
    - button, 25
  - IR receiver
    - location, 5
- M**
  - menu
    - button, 25
  - midnight mode, 30
  - movie rating
    - parental control, 32
  - mute
    - button, 25
- N**
  - NTSC
    - connecting, 17
    - connector, location, 7
- O**
  - optical digital out
    - connector, location, 7
- OSD**
  - audio menu, 30
  - hold time, 33
  - parental control menu, 32
  - picture menu, 30
  - PIP/POP/PBP, 31
  - setup menu, 33
  - size menu, 32
- P**
  - parental control, 32
    - about, 32
    - block options, 32
    - channel lock, 32
    - movie rating, 32
  - PICT
    - button, 25
  - picture by picture. See PIP/POP/PBP
  - picture in picture. See PIP/POP/PBP
  - picture menu
    - color temperature, 30
    - movies, 30
    - multimedia, 30
    - sports, 30
    - weak signal, 30
  - picture on picture. See PIP/POP/PBP
  - PIP
    - button, 25
  - PIP SEL
    - button, 25
  - PIP/POP/PBP
    - compatibility, 31
    - setting up, 31
  - plasma conditioning, 33, 39
  - POP/PBP
    - button, 25
  - POS
    - button, 25
  - power
    - connector, location, 8
  - power LED
    - location, 5
- R**
  - remote control
    - audio button, 25
    - enter button, 25
    - guide button, 25
    - INFO button, 25
    - input button, 25

- installing batteries, 23
- menu button, 25
- mute button, 25
- PICT button, 25
- PIP button, 25
- PIP SEL button, 25
- POP/PBP button, 25
- POS button, 25
- sleep button, 25
- swap button, 25
- troubleshooting, 40
- universal, using, 26
- using, 24

## S

- self-test
  - using, 41
- Sequential, 31
- sequential
  - POP scan mode, 31
- setup
  - channel setup, 33
  - channels, 33
  - DVI settings, 33
  - menu, 33
  - OSD hold time, 33
- size
  - 4 to 3, 32
  - full screen, 32
  - menu, 32
  - PIP/POP/PBP window, 31
  - standard, 32
  - wide, 32
  - zoom, 32
- sleep

- button, 25
- SPDIF. See optical digital out
- speaker out
  - connectors, location, 8
- specifications, 43
  - audio, 45
  - general, 43
  - inputs, 44
  - outputs, 44
  - physical dimensions, 43
  - picture-in-picture (PIP), 44
  - viewing angle, 44

SRS TruSurround XT, 30

- subwoofer
  - connector, location, 7

- S-Video
  - AV3/AV4 connectors,
    - location, 7
  - cable, usage, 15
  - connecting, 17-18
  - connector, location, 6

- swap
  - button, 25

## T

- tips
  - troubleshooting, 35
- transparency
  - of PIP/POP/PBP window, 31
- troubleshooting, 35
  - general problems, 36
  - remote control, 40
  - self-test, 41
  - tips, 35

VGA monitor, 41

- TV
  - about, 5
  - bottom view, 7
  - caring for, 11
  - front view, 5
  - proper location, 13
  - right view, 6
  - setting up, 13
  - troubleshooting, 35
- TV ratings, 32
  - parental control, 32

## V

- VGA
  - connecting, 18
  - connector, location, 8
- volume
  - fixed, 30
  - variable, 30

## W

- weak signal, 30